



6R2Z

Type A+DC6mA RCD sensor

版本: V1.04



Overview

6R2Z residual current sensor is designed for use in AC EV charging stations, enabling Type B functionality while complying with Type A + 6 mA requirements. It features a digital output and offers high accuracy, low temperature drift, and strong immunity to interference. Its functionality meets the relevant IEC and GB requirements for EV charging applications. 6R2Z integrates current transformer as well.

Key Features

- Digital output
- Built-in self-test function
- 5 V power supply
- Low temperature drift

Standards Compliance

- IEC 62955 – Residual direct current detecting devices (RDC-DD) for permanently connected AC electric vehicle charging stations
- IEC 61851 – Electric vehicle conductive charging system
- IEC 62752 – In-cable control and protection device (IC-CPD) for Mode 2 charging of electric road vehicles
- GB/T 40820 – DC residual current detecting devices (RDC-DD) for Mode 3 charging of electric vehicles
- GB/T 22794 – Type F and Type B residual current operated circuit-breakers, with or without overcurrent protection, for household and similar use

Absolute Maximum Ratings

Parameter	Unit	Min	Max	Notes
VCC	V	-0.3	6	Supply Power
TA	°C	-40	85	Operate Temperature
TA-S	°C	-40	105	Storage Temperature

Electrical Characteristics

Ta=25°C, Vcc=5V					
Parameter	Symbol	Min	Typ	Max	Unit
Supply Voltage	Vcc	4.8	5	5.2	V
Current Consumption	IC	-	14	-	mA
TRIP Voltage (Output)	VH	4.2	5	5	V
	VL	0	-	0.6	V
CLK&CHK Voltage (Input)	VH	4.2	-	Vcc	V
	VL	0	-	0.5	V
Operate Temperature	TA	-40	-	85	-
Storage Temperature	TA-S	-40	-	105	-
Weight	m	-	30	-	g
Startup time	Ton	-	-	800	ms
Residual Current Trip Current					
Parameter	Symbol	Min	Typ	Max	Unit
DC_SM	-	3	4.5	6	mA
AC (50HZ)	-	15	22	30	mA
A0° (50HZ)	-	10.5	22	42	mA
A90° (50HZ)	-	7.5	22	42	mA
A135° (50HZ)	-	3.3	28	42	mA
2PDC	-	3.5	5.5	7	mA
3PDC	-	3.1	4.5	6.2	mA
F IC_CPD	-	15	28	42	mA
Residual Current Trip Time					

Parameter	Symbol	Min	Typ	Max	Unit
DC 6mA	-	-	380	650	ms
DC 60mA	-	-	63	80	ms
DC 300mA	-	-	11	28	ms
AC 30mA	-	-	115	200	ms
AC 60mA	-	-	63	80	ms
AC 150mA	-	-	15	28	ms
A0 42mA	-	-	68	150	ms
A0 84mA	-	-	50	100	ms
A0 350mA	-	-	13	28	ms
A0 42mA +6mADC	-	-	73	200	ms
A0 84mA +6mADC	-	-	46	100	ms
A0 350mA +6mADC	-	-	14	28	ms
2PDC/3PDC 60mA	-	-	63	100	ms
2PDC/3PDC 120mA	-	-	18	80	ms
2PDC/3PDC 300mA	-	-	12	28	ms
F IC_CPD 210mA	-	-	15	28	ms

Operating Instructions

1. Conduct a self-test CLK&CHK calibration once upon power-on and another prior to charging.
2. The RCD sensor has an 800ms delay immediately after power-on, during which no response or processing will be performed.
3. The RCD sensor calculates the zero point during power-on and self-test.
4. It is recommended that VCC be generated by a 5V LDO, with a ripple voltage of less than 30mV.
5. The RCD sensor should be installed at the output terminal of the charging pile.

6. The RCD sensor shall be placed at a distance of more than 3cm from the relay.

Dimensions (Unit: mm)

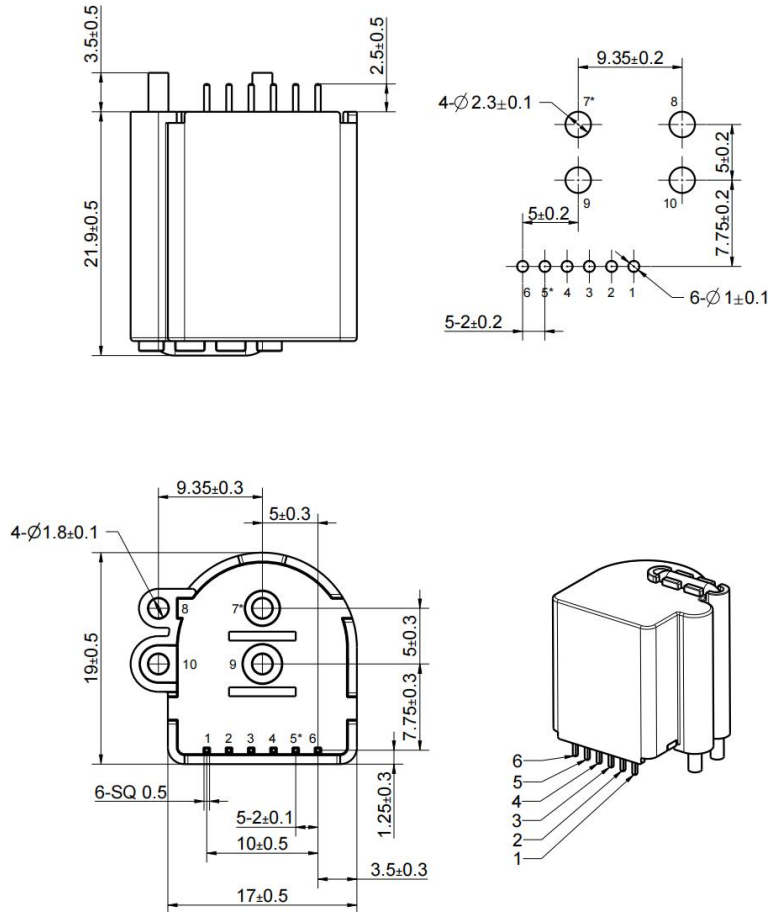

Pin definition		
No.	Definition	Description
1	VCC	5V
2	TRIP	Outputs a high level when leakage current is detected; otherwise, it remains at a low level.
3	GND	GND
4	CLK&CHK	CLK&CHK, timing diagram see as below
5	CT	CT pin1
6	CT	CT pin2

Self Check Timing Diagram

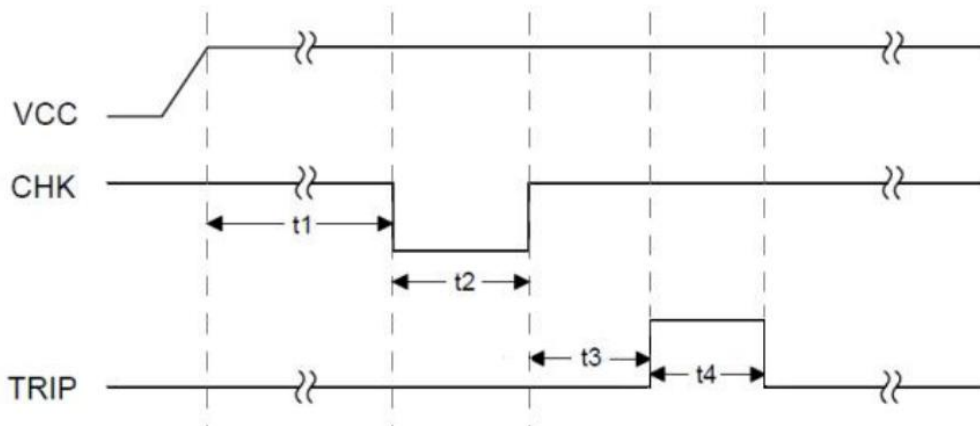

To Ensure High Precision and Operational Stability of the Sensor, the Following Parameters for t1, t2, t3 and t4 Are Recommended

1. t1: Waiting time after power-on completion ($t1 \geq 1s$ recommended)
2. t2: Time for the sensor to trigger the zero-clearing & self-test function ($0.6s \leq t2 \leq 1.2s$)
3. t3: Waiting time for the sensor to complete zero-clearing ($380ms \leq t3 \leq 450ms$)
4. t4: Sensor self-test time ($200ms \leq t4 \leq 400ms$). After the level of the TRIP pin flips to low level, the normal residual current detection workflow shall be initiated.

Note: During calibration and zero-clearing, the main relay of the charging pile shall be closed only after the TRIP signal output is completed.

Reference circuit

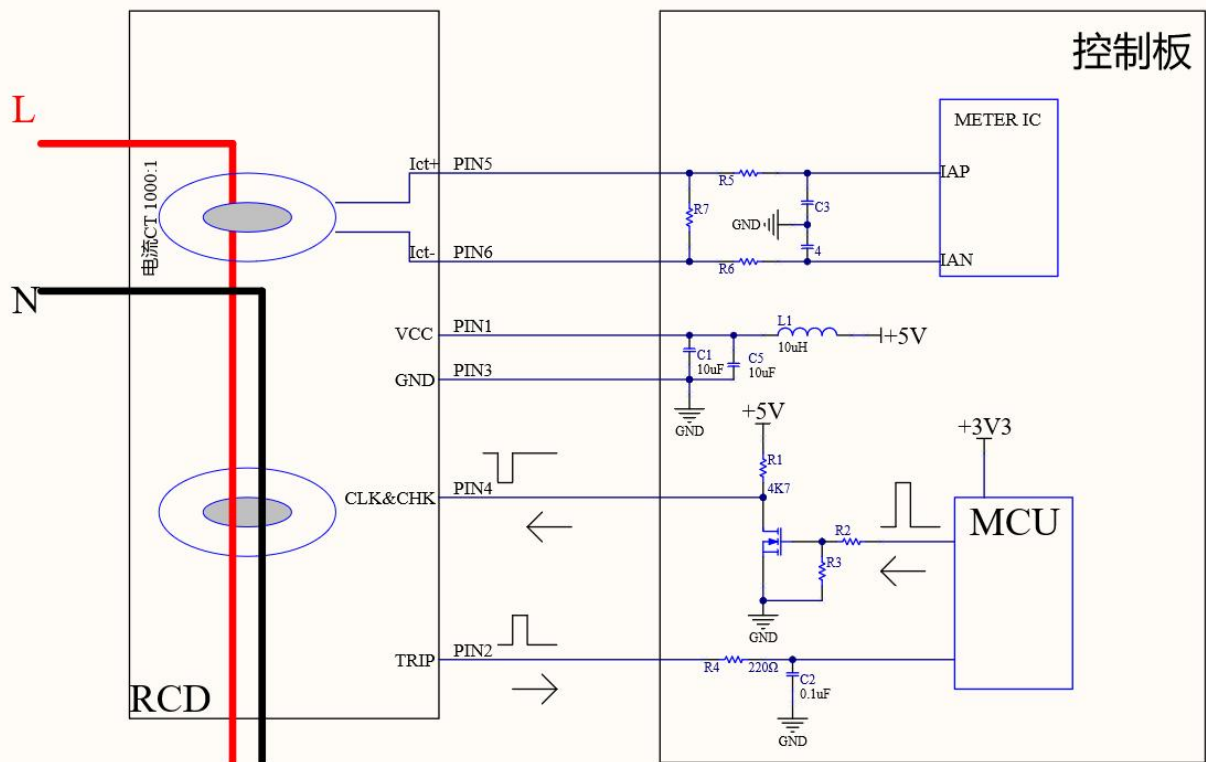

Transformer Parameter

No	Function	Parameter	Unit
01	Rated frequency	50/60	Hz
02	Rated input current	16	A
03	Rated output current	16	mA
04	Rated load	10	Ω
05	Maximum input current	20	A
06	Ratio error limit	$< \pm 0.2$ (100%)	
07	AC withstand voltage	There is no breakdown or arcing phenomenon between the primary winding and the secondary winding.	AC2.5kV, 1min, leakage current $< 1\text{mA}$
08	Insulation resistance	Between primary and secondary $\geq 1000\text{M}\Omega$	500VDC
09	Operating temperature	-40 ~ +105	$^{\circ}\text{C}$

10	Relative humidity	≤ 95%	
----	-------------------	-------	--

Warranty

The RCD sensor has undergone rigorous quality inspection. Any product quality issues can be reported to the distributor within one year from the date of purchase.

Any direct damage or malfunction caused by user negligence, improper use, incorrect installation, unauthorized maintenance or natural wear and tear is not covered by the warranty.

Version History

Version	Description	Date
V1.0	初版	2024.08.11
V1.01	文字勘误	2024.12.26
V1.02	增加参考电路	2025.03.06
V1.03	建议BUCK电源增加LC滤波	2025.09.21
V1.04	增加尺寸标注	2025.10.12