

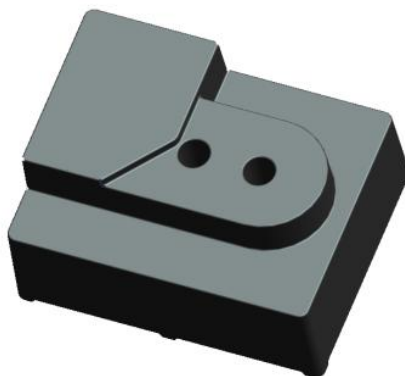

2R4Z

Type A+DC6mA RCD sensor

Version: V1.04



Overview

The 2R4Z residual current sensor is designed for use in AC EV charging stations, enabling Type B functionality while complying with Type A + 6 mA requirements. It features a digital output and offers high accuracy, low temperature drift, and strong immunity to interference. Its functionality meets the relevant IEC and GB standards for EV charging applications. In addition, the 2R4Z integrates both voltage and current transformers.

Key Features

- Digital output
- Built-in self-test function
- 5 V power supply
- Low temperature drift

Standards Compliance

- IEC 62955 – Residual direct current detecting devices (RDC-DD) for permanently connected AC electric vehicle charging stations
- IEC 61851 – Electric vehicle conductive charging system
- IEC 62752 – In-cable control and protection device (IC-CPD) for Mode 2 charging of electric road vehicles
- GB/T 40820 – DC residual current detecting devices (RDC-DD) for Mode 3 charging of electric vehicles
- GB/T 22794 – Type F and Type B residual current operated circuit-breakers, with or without overcurrent protection, for household and similar use

Absolute Maximum Ratings

Parameter	Unit	Min	Max	Notes
VCC	V	-0.3	6	Supply Power
TA	°C	-40	85	Operate Temperature
TA-S	°C	-40	105	Storage Temperature

Electrical Characteristics

Ta=25°C, Vcc=5V					
Parameter	Symbol	Min	Typ	Max	Unit
Supply Voltage	Vcc	4.8	5	5.2	V
Current Consumption	IC	-	14	-	mA
TRIP Voltage (Output)	VH	4.2	5	5	V
	VL	0	-	0.6	V
CLK&CHK Voltage (Input)	VH	4.2	-	Vcc	V
	VL	0	-	0.5	V
Operate Temperature	TA	-40	-	85	-
Storage Temperature	TA-S	-40	-	105	-
Weight	m	-	30	-	g
Startup time	Ton	-	-	800	ms
Residual Current Trip Current					
Parameter	Symbol	Min	Typ	Max	Unit
DC_SM	-	3	4.5	6	mA
AC (50HZ)	-	15	22	30	mA
A0° (50HZ)	-	10.5	22	42	mA
A90° (50HZ)	-	7.5	22	42	mA
A135° (50HZ)	-	3.3	28	42	mA
2PDC	-	3.5	5.5	7	mA
3PDC	-	3.1	4.5	6.2	mA
F IC_CPD	-	15	28	42	mA

Residual Current Trip Time					
Parameter	Symbol	Min	Typ	Max	Unit
DC 6mA	-	-	380	650	ms
DC 60mA	-	-	63	80	ms
DC 300mA	-	-	11	28	ms
AC 30mA	-	-	115	200	ms
AC 60mA	-	-	63	80	ms
AC 150mA	-	-	15	28	ms
A0 42mA	-	-	68	150	ms
A0 84mA	-	-	50	100	ms
A0 350mA	-	-	13	28	ms
A0 42mA +6mADC	-	-	73	200	ms
A0 84mA +6mADC	-	-	46	100	ms
A0 350mA +6mADC	-	-	14	28	ms
2PDC/3PDC 60mA	-	-	63	100	ms
2PDC/3PDC 120mA	-	-	18	80	ms
2PDC/3PDC 300mA	-	-	12	28	ms
F IC_CPD 210mA	-	-	15	28	ms

Operating Instructions

1. Conduct a self-test CLK&CHK calibration once upon power-on and another prior to charging.
2. The RCD sensor has an 800ms delay immediately after power-on, during which no response or processing will be performed.

3. The RCD sensor calculates the zero point during power-on and self-test.
4. It is recommended that VCC be generated by a 5V LDO, with a ripple voltage of less than 30mV.
5. The RCD sensor should be installed at the output terminal of the charging pile.
6. The RCD sensor shall be placed at a distance of more than 3cm from the relay.

Dimensions (单位: mm)

P/N: **2R4Z**

Dimensions: 49.2*37.7*24.7mm

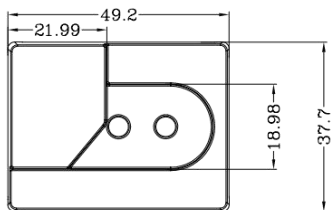
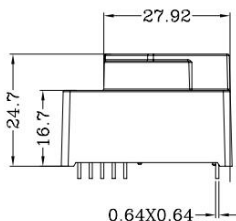
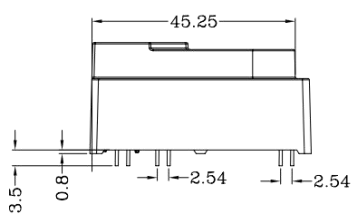
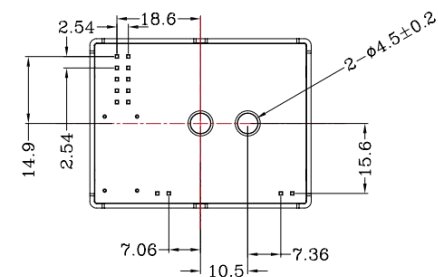

Pin definition					
No	Symbol	Definition	No	Symbol	Definition
1	Vct+	Voltage Transformer+	7	Ict-	Current Transformer-
2	Ict+	Current Transformer+	8	GND	地
3	VCC	5V	9	NC	NC
4	TRIP	Digital Output	10	NC	NC
5	CLK&CHK	CLK&CHK	11	N	N
6	Vct-	Voltage Transformer-	12	L	L

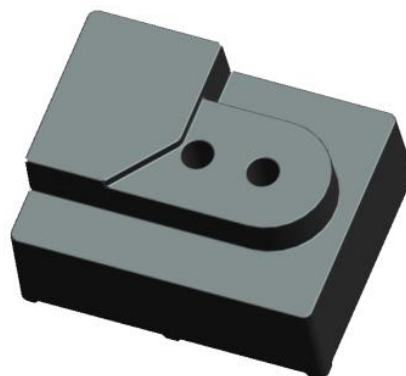

Self Check Timing Diagram

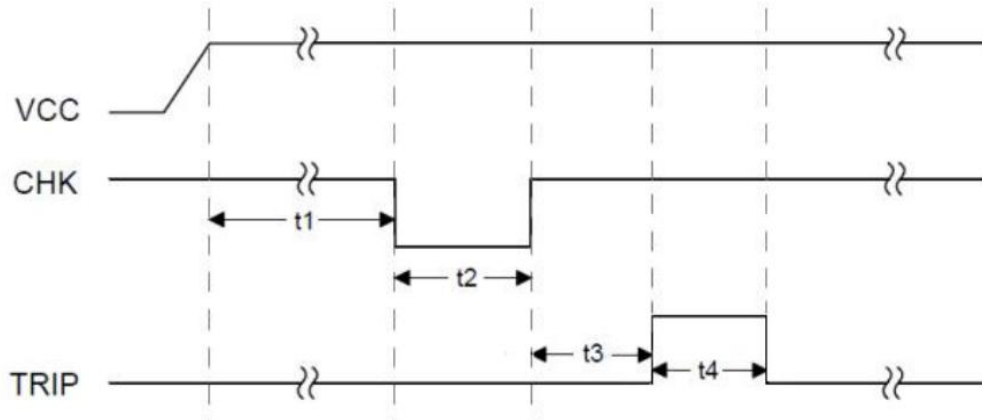

To Ensure High Precision and Operational Stability of the Sensor, the Following Parameters for t1, t2, t3 and t4 Are Recommended

1. t1: Waiting time after power-on completion ($t1 \geq 1s$ recommended)
2. t2: Time for the sensor to trigger the zero-clearing & self-test function ($0.6s \leq t2 \leq 1.2s$)
3. t3: Waiting time for the sensor to complete zero-clearing ($380ms \leq t3 \leq 450ms$)
4. t4: Sensor self-test time ($200ms \leq t4 \leq 400ms$). After the level of the TRIP pin flips to low level, the normal residual current detection workflow shall be initiated.

Note: During calibration and zero-clearing, the main relay of the charging pile shall be closed only after the TRIP signal output is completed.

Reference circuit

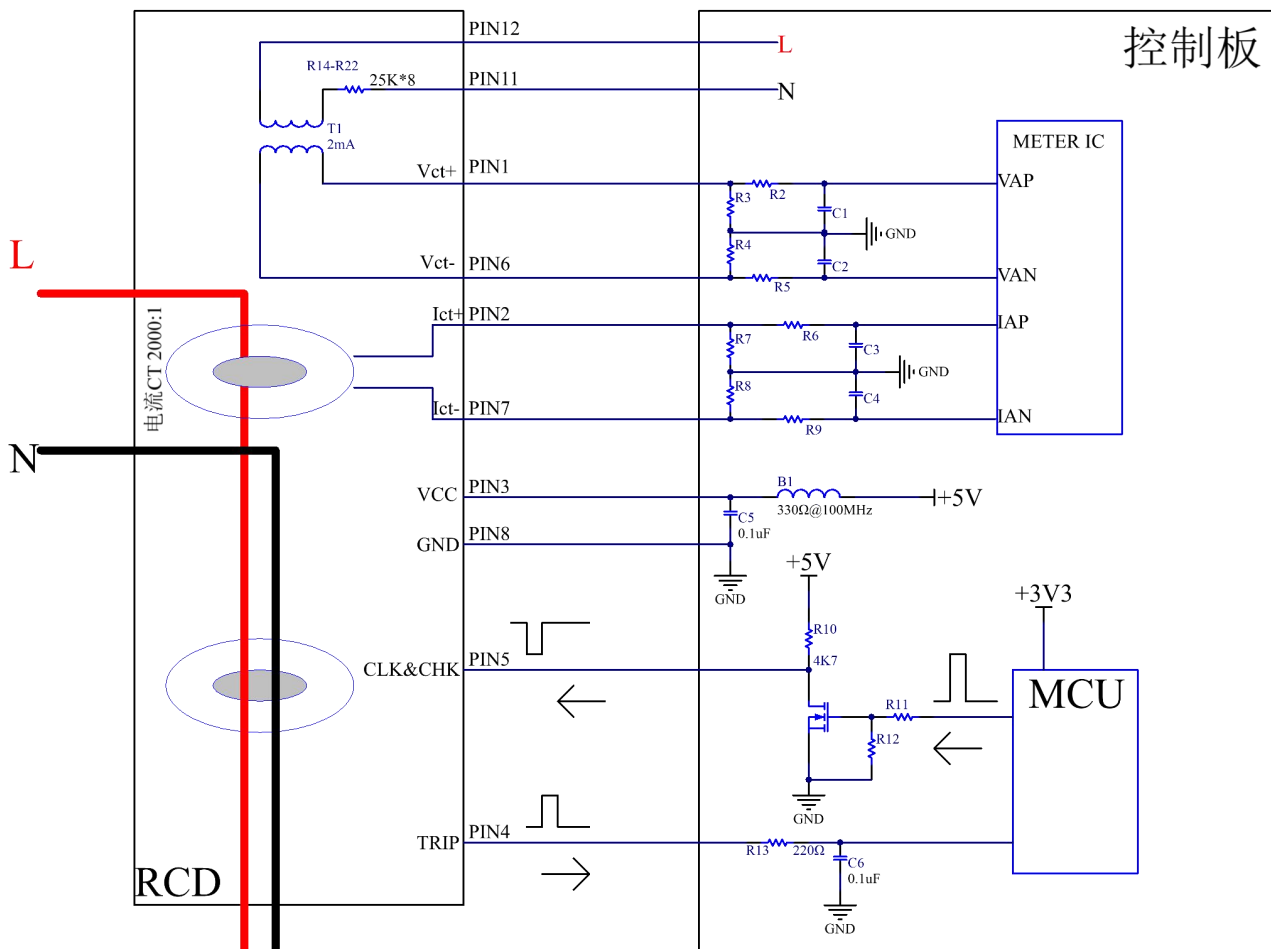

Transformer Parameter

Voltage Transformer	
Rated primary: 2mA	Phase displacement: $\leq 45^\circ$
Rated secondary: 2mA	Withstand voltage: 4KV
Frequency: 45...1.25KHz	Linearity: 5...120%IPN
Ratio error@RL=0Ω: $\leq \pm 0.2\%$	Turns ratio: 1000:1000

Current Transformer (Load Resistor 10R, -40~85°C)	
Rated primary: 40A	Ratio error: $\leq \pm 0.2\%$
Rated secondary: 20mA	Withstand voltage: 5KV
Frequency: 45...400Hz	Linearity: 0...130%IPN
Phase displacement: $< 10'$	Turns ratio: 1:2000

Warranty

The RCD sensor has undergone rigorous quality inspection. Any product quality issues can be reported to the distributor within one year from the date of purchase.

Any direct damage or malfunction caused by user negligence, improper use, incorrect installation, unauthorized maintenance or natural wear and tear is not covered by the warranty.

Version History

Version	Description	Date
V1.0	初版	2023.03.11
V1.01	文字勘误	2023.08.26
V1.02	增加参考电路	2023.12.24
V1.03	建议漏电环放于输出端	2024.05.12
V1.04	图纸增加一个尺寸	2025.03.10